

The background of the page is a decorative graphic consisting of numerous thin, parallel red lines that curve and flow across the page, creating a sense of motion and depth. The lines are more densely packed in some areas, creating a gradient of red intensity.





**Explosion-proof Dual-spectrum Camera  
Quick Start Guide  
V1.0.2**

## Preface

The following is about the correct use of the camera. In order to prevent danger and loss of property, please read this manual carefully before using the camera and strictly follow it during use. Please keep the manual properly after reading.

### Symbol Description

For the symbols that appear in the document, the description is as follows.

 <b>Note</b>	The instructions are an emphasis and supplement to the main text.
 <b>Caution</b>	Cautions indicates potential risks. If ignored, it may lead to product damage, data loss, product performance degradation, or unpredictable results.
 <b>Warning</b>	Warnings indicates that low or medium potential risk is existing. The ignorance of the warnings may lead to light or medium damage for people.
 <b>Danger</b>	Dangerous text indicates that there is a high potential risk. If it is not avoided, a major risk of personal injury or even death may be caused.

### Important Safety Notice

#### Warnings

The local electrical safety standards should be rigorously followed in the process of installation and usage.

- Please use power adapter which is produced by regular companies. Please check whether the power is normal or not before starting the camera. (Power supply requirements should comply with that on the

product labels.)

- In order to make emergency power off when necessary, please install power-off equipment which is easy to use when installing the wires.
- Please protect power lines from being treaded or pressed, especially the connecting points which are led from the plug, power socket or other unit.
- Please make sure the camera is fixed firmly in case of being installed on walls or ceilings.
- If the camera does not work normally, please contact the purchased shops or factories. Do not disassemble or revise the camera in any way (The manufacturing company is not responsible for problems that are caused by unauthorized modification or maintenance.)



### **Cautions**

- Please do not put the camera in damp, dusty, extremely hot or cold places, or places with corrosive gas or unstable light.
- Please transport, use and store the camera within the allowable humidity and temperature range.
- Avoid making the lens aiming at strong light (e.g. sun or laser), otherwise the imaging sensor would be damaged.
- Please do not block the vents near the camera in case of heat accumulated.
- Please use the factory packaging or materials of the same quality when shipping the device.
- Please do not press, vibrate violently or soak the camera during transportation, storage or installation.
- It is advised to use the camera with lighting protector.

- Soft dry cloth can be used to clean the camera. For the dirt difficult to clean, please use soft cloth with little neutral detergent and then wipe dry. Do not use volatile detergent like alcohol, benzene or diluent, or strong and abrasive detergent, otherwise the camera coating would be damaged and also the camera performance could be degraded.
- The lens cover is optical device, so please do not touch directly or wipe the cover. Soft brush or hairdryer can be used to blow the dust away. For the grease or fingerprint, soft cloth can be used to wipe it away. Cotton cloth or lens cleaning paper with cleaning solution can be used to wipe repeatedly until it's clean.
- Please revise the password promptly after logging in.



### **Instruction**

- Please use the accessories or parts specified by the manufacturer and have them installed and repaired by professional service personnel.
- Quality requirements for installation and maintenance personnel:  
 Personnel should have the qualification certificate or experience to engage in the installation and maintenance of video surveillance systems, and have the qualification to engage in related jobs (such as high-altitude operations, etc.), in addition to the following knowledge and operating skills.  
 Equipped with basic knowledge and installation skills of video surveillance system and its components.  
 Equipped with basic knowledge and operating skills of low-voltage wiring and low-voltage electronic circuit wiring.  
 Equipped with basic network security knowledge and skills, and have good acknowledge of this manual.
- Requirements for lifting equipment:

Safe lifting equipment suitable for site and method of camera installation.

The lifting equipment is able to reach enough height of installation position.

The lifting equipment has good safety performance.

# Table of Contents

1. Camera Description .....	- 1 -
1.1 Camera Appearance .....	- 1 -
1.2 Cable Description .....	- 1 -
1.3 Alarm Interface Connection .....	- 4 -
2.Camera Installation .....	- 5 -
2.1 Instructions before Installation .....	- 5 -
2.2 Recommended Monitoring Distance .....	- 6 -
2.3 Installation Guide .....	- 7 -
2.3.1 Installation Precautions .....	- 7 -
2.3.2 Installation Procedures .....	- 7 -
2.3.3 Mounting Effect .....	- 9 -
3.Operation Guide .....	- 10 -
3.1 Preparations .....	- 10 -
3.2 Login System .....	- 11 -
3.3 Main Interface Description .....	- 12 -
Appendix A Camera Maintenance .....	- 13 -
Appendix B Emissivity of Common Materials .....	- 14 -

# 1. Camera Description

## 1.1 Camera Appearance

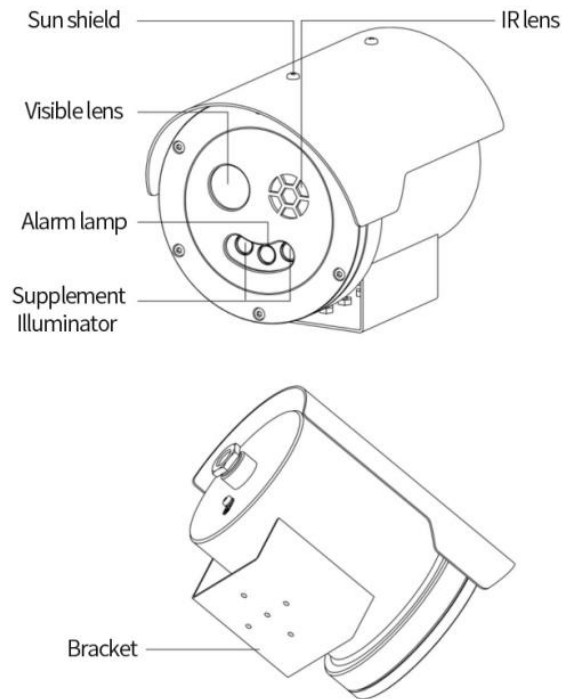

**Figure 1.1 Product Appearance and Interface**

## 1.2 Cable Description

The product provides two kinds of power supply models (AC/DC), the cable includes interfaces for power, alarm, audio, RS-485, and RJ-45 network, optical fiber communication, power, audio, alarm, RS-485 etc. Please see figure 1.2 and figure 1.3 for interface descriptions, refer to table 1-1 for detailed descriptions.

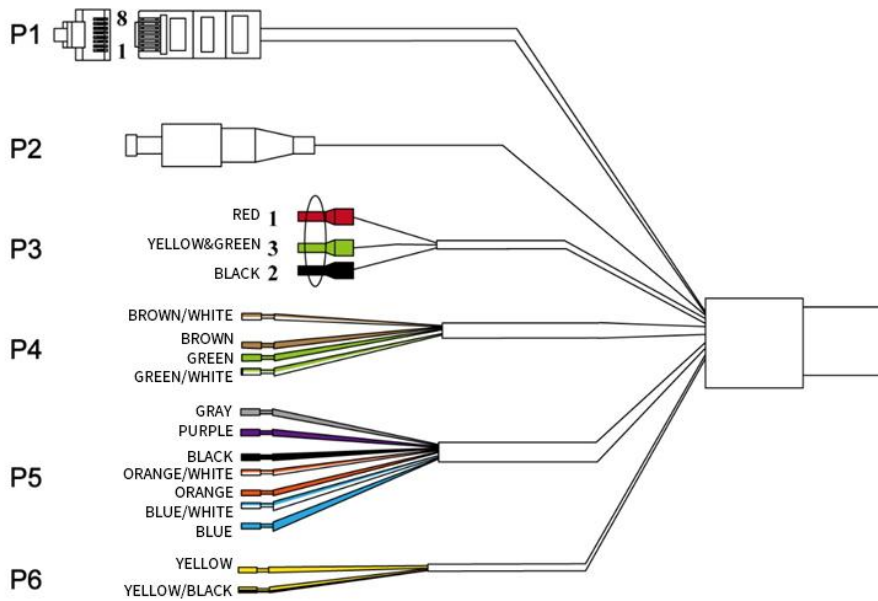

Figure 1.2 Cable Descriptions (AC)

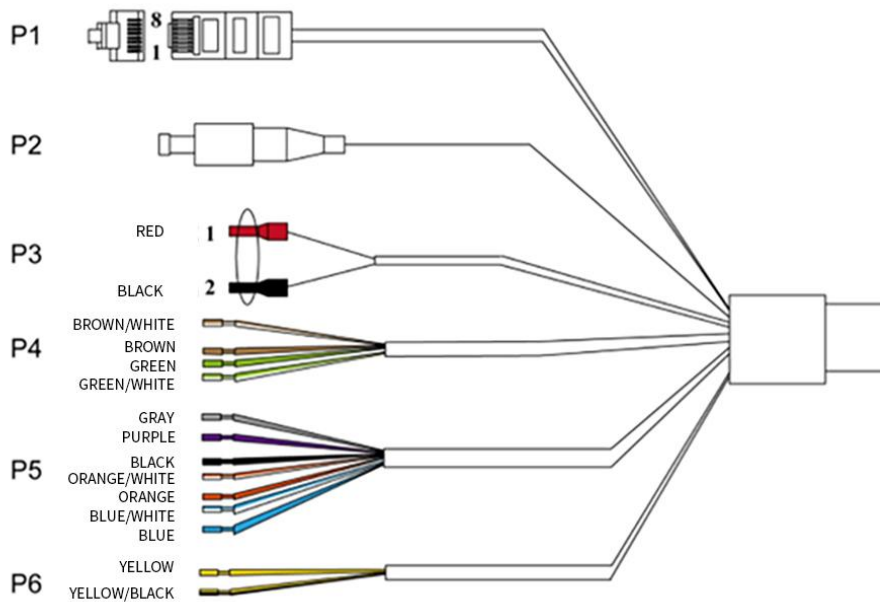

Figure 1.3 Cable Descriptions (DC)

Table 1-1 Table of Detailed Cable Descriptions

	Interface	Interface Name	Connector	Wire Map	Function Descriptions
P1	RJ45	Network Interface	Ethernet port	-	Network signal output, connect with standard Ethernet cable
P2	FC	Fiber Communication Interface	Fiber Optical Transceiver	-	Fiber signal output, FC interface



			(100M,wavelength h: 1550)		
P3-1 *	POWER	AC 220V	-	1.RED	Power interface, AC 220V input Note: make sure to supply power according to the labelling, incorrect operation would damage the device.
		AC 220V	-	2.BLACK	
		GND	-	3. YELLOW&G REEN	
P3-2 *	POWER	DC 12V+	-	1.RED	Power interface, input DC 12V Note: make sure to supply power according to the labelling, incorrect operation would damage the device.
		DC 12V-	-	2. BLACK	
P4	Audio	AUDIO IN	-	1.BROWN	Input audio signal, with external Microphone connection, receive linear analog audio signals for sound collection.
		GND	-	2. BROWN/WHI TE	Audio IN GND
		AUDIO OUT	-	3. GREEN	Output audio signals to loudspeaker for sound output
		GND	-	4.GREEN/WH	Audio OUT GND

				ITE	
P5	Alarm	ALARM IN1	alarm apparatus, such as smoke detector, alarm whistle, etc	1. GRAY	Alarm input interface to receive external alarm signals
		ALARM IN2		2. PURPLE	
		GND		3. BLACK	Alarm GND
		ALARM OUT1		4. ORANGE/WH ITE	Alarm output interface to output alarm signals to alarm devices.
		ALARM COM1		5. ORANGE	The first alarm output channel
		ALARM OUT2		6. BLUE	The second alarm output channel
		ALARM COM2		7. BLUE/WHITE	
P6	RS485	RS485 D+	-	2. YELLOW	Used to connect RS-485 peripherals
		RS485 D-	-	1 YELLOW/BL ACK	

**Note:** \* the AC/DC power solution is applicable for different models, use as needed.

### 1.3 Alarm Interface Connection

The camera can be connected to alarm switch signal (0~DC 5V) input and switch output (no voltage). An external power supply is required when connecting the alarm. The specific wiring method is shown in the figure below.

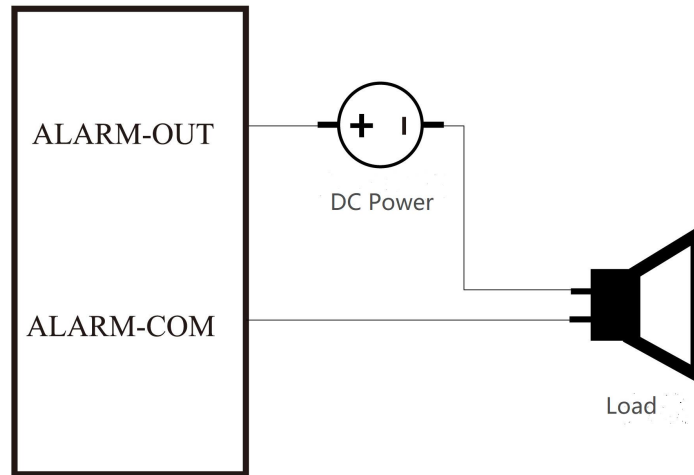

Figure 1.4 Alarm Output Wiring Method

## 2. Camera Installation

### 2.1 Instructions before Installation

Before installation, please check whether the ambient temperature, humidity, cleanliness, anti-interference and thunder-proof meet the requirement and whether the power supply is safe.

- Do not disassemble the structural components of the explosion-proof equipment, otherwise the waterproof performance of the explosion-proof products will be affected. Please operate according to the requirements described in the manual.
- Be sure to use a specified power supply.
- Use the product within the specified range of atmospheric pressure, ambient temperature and humidity.
- Due to the particularity of explosion-proof products, it is recommended to power up and debug first, and then install them on the spot after getting familiarized with the performance.
- Do not place any additional load on the device, otherwise it may exceed the carrying capacity of the device and cause functional failure or damage to the device.

- Parts that may affect explosion-proof performance are not allowed to be changed after passing quality inspection.
- The product is equipped with special internal and external grounding, grounding wire resistance should be less than  $1\Omega$ , grounding resistance should be less than  $1\Omega$ . The users should connect correctly, ungrounded connection is strictly prohibited, otherwise you should bear the consequences by yourselves.

## 2.2 Recommended Monitoring Distance

Since the thermal imaging channel of the camera adopts a fixed-focus athermalized lens, remote electric focusing can not be realized. Therefore, before installing the camera, please select the corresponding installation position and lens focal length according to the monitoring requirements to achieve the purpose of monitoring.

The reference table of lens focal length and monitoring distance is shown in the following table.

Table 2-1 Recommended Monitoring Distance (12 $\mu$ m Pixel)

Equipped Lens	DD (Vehicle)	DD (Human)	RD (Vehicle)	RD (Human)	ID (Vehicle)	ID (Human)
9.1mm	1163m	379m	291m	95m	145m	47m
13mm	1661m	542m	415m	135m	208m	68m
19mm	2428m	792m	607m	198m	303m	99m
25mm	3194m	1042m	799m	260m	399m	130m

- If the weather is clear and the visibility is normal, without visible fog or haze, there is a 50% chance of reading the target at the specified distance.
- Assume that the width of the people is 0.5m, the height is 1.8m, and the critical distance is 0.75m. In case of the width of the vehicle is 4.0m, the

height is 1.4m, and the critical distance is 2.3m.

- According to the Johnson criterion of infrared images, suppose:  
The detection target needs to be imaged at least 1.5 pixels in the critical direction.  
Recognizing the target needs to image no less than 6 pixels in the critical direction.  
Recognizing the target requires imaging no less than 12 pixels in the critical direction.
- The actual detection distance varies with the settings of the thermal camera, environmental conditions, user experience, monitoring or displaying type.

## **2.3 Installation Guide**

Pole mounting, wall mounting or ceiling mounting is supported, and the camera can be installed in different ways according to different installation environment.

### **2.3.1 Installation Precautions**

- Complete debugging will be made before product delivery, the product just needs to be mounted to the designated place;
- The users should confirm the installation location to ensure that the space is enough to install both the device and the structural parts, the bearing capacity of the walls and supports, and the total bearing weight.
- The device should be installed in an area out of human reach, no obstructing objects in the camera's field of view, otherwise the device may fall or be damaged, or even bring great danger in personal safety.

### **2.3.2 Installation Procedures**

**Step 1** Installation of Explosion-proof Flexible Hose

The cable should pass through the components in turn as shown in the figure (the connector has already been welded to the product), and secure each component.

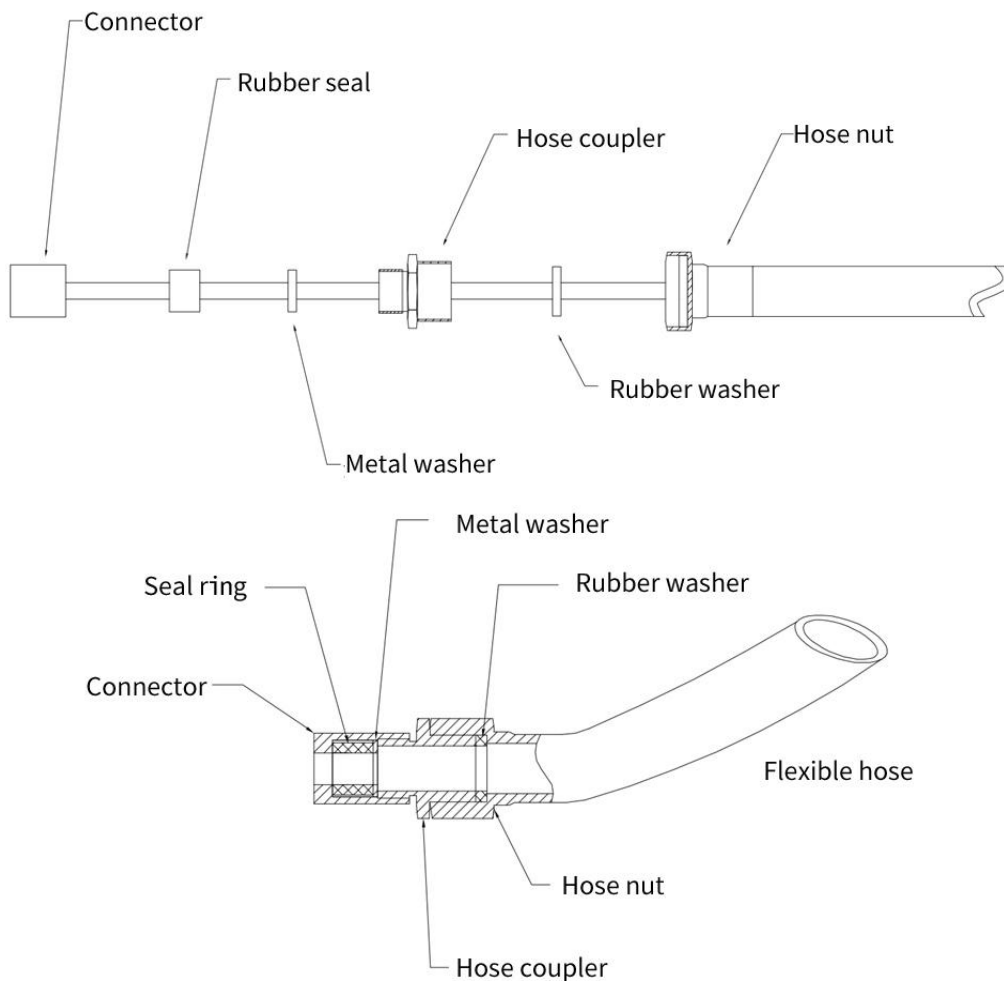

**Figure 2.3 Installation of Flexible Hose**

### **Step 2 Installation of Brackets**

- Choose compatible bracket mounting holes;
- Install the device after the angle adjustment.
- Secure the bracket with qualified Anka anchor bolt or expansion screws.  
Explosion-proof junction boxes should be installed in a place for easy mounting and maintenance.

**Note: when the cable is connected to the control cabinet, it must be protected by explosion-proof flexible hose (armored cable can also be used). The cable connecting the junction box to the control cabinet must be protected by metal pipe, or use armored cable directly.**

### Step 3 Installation

- Fasten M6\*16 inner hexagon screw sets to the fixing hole on the mounting plate and secure by matching to the fixing nut on the U-shaped bracket of the housing.
- Fix the cardan joint to the specified position with M6\*16 inner hexagon screw sets, and then fix the device to the specified hole on the upper surface of the cardan joint with M6\*16 inner hexagon screw sets (the tilt angle can be adjusted by loosening the inner hexagon screw sets on the side of the cardan joint).
- First fix the bracket on the wall with M8\*80 expansion bolts, then fix bracket and cardan joint with M6\*16 inner hexagon screw sets, finally fix the device to the specified hole on the upper surface of the cardan joint with M6\*16 inner hexagon screw sets (the tilt angle can be adjusted by loosening the inner hexagon screw sets on the side of the cardan joint).

### 2.3.3 Mounting Effect

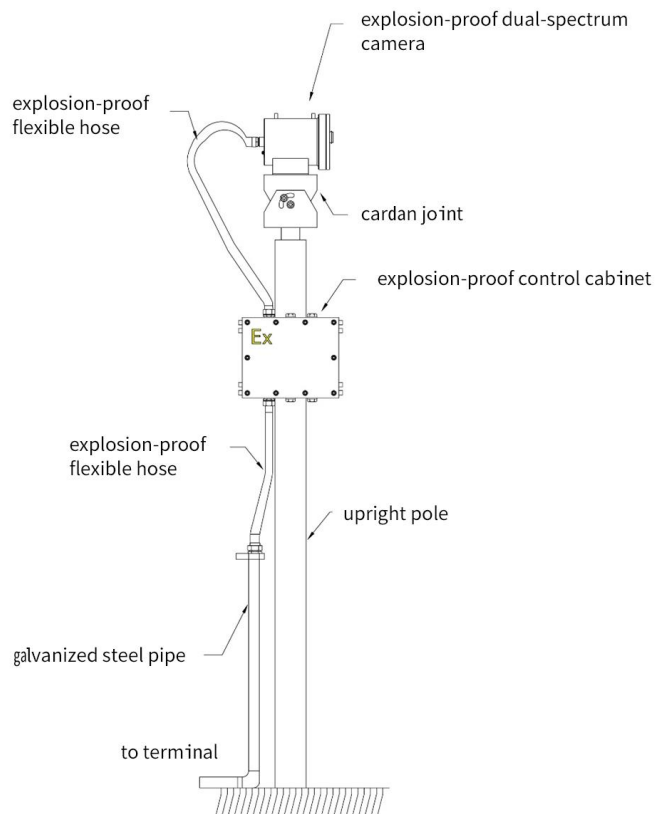

**Figure 2.4 Pole Mounting**

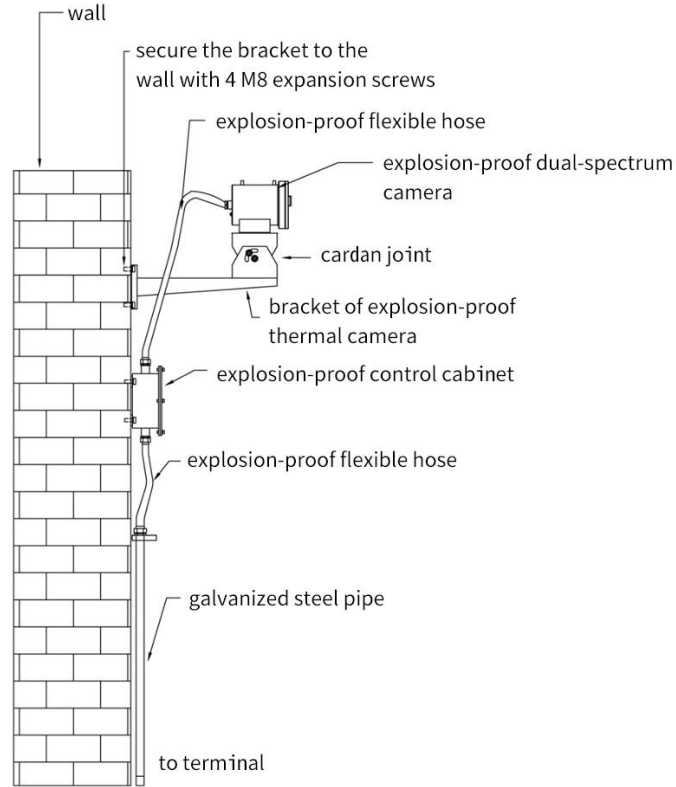

**Figure 2.5 Wall Mounting**

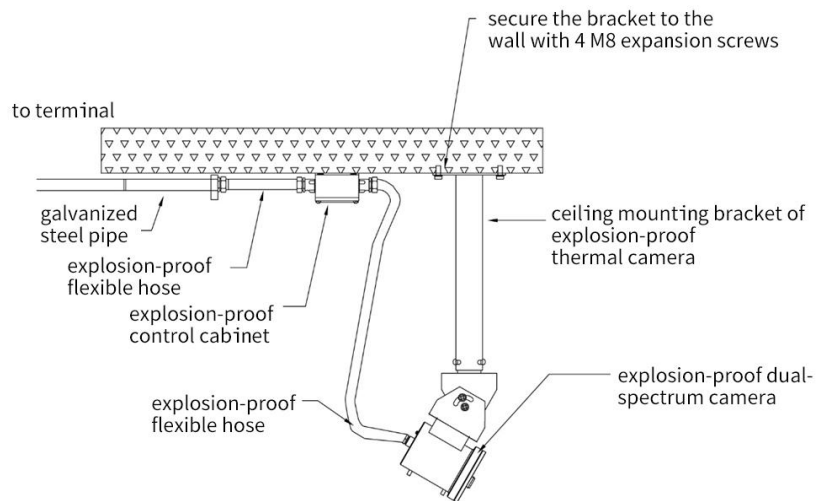

**Figure 2.6 Ceiling Mounting**

## 3.Operation Guide

### 3.1 Preparations



1. The default IP address of the device: 192.168.1.123.
2. The subnet mask is 255.255.255.0, and the IP address of the camera can be modified. If you change the device address to 192.168.1.194, change your computer's IP address to the same network segment with the network video server, and the same subnet mask. Such as: 192.168.1.120.
3. Test whether the device starts normally. Under WINDOWS, follow the <Start→run→cmd> operation, open the command line window, and enter Ping 192.168.1.123 in the command line window. If "Request time out" is not displayed, it means the startup is normal.

## 3.2 Login System

1. Enter the IP address of the camera in the address bar of the IE browser to log in, and the login page is as shown below, you can change the language between simplified Chinese and English on the interface.

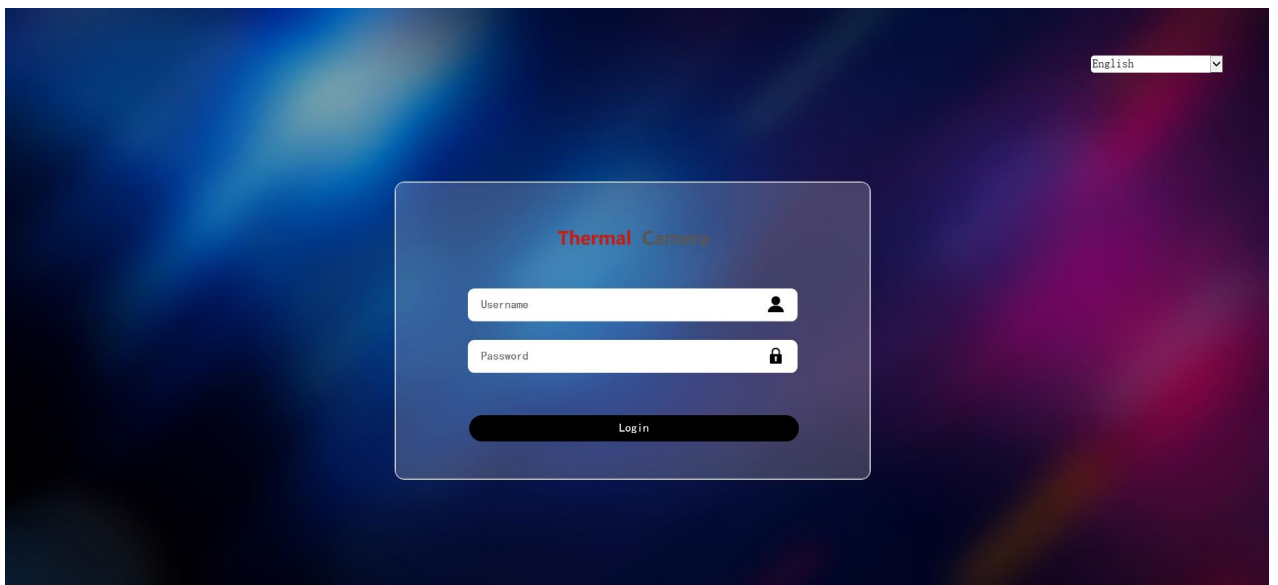

**Figure 3.1 Login Interface**

2. For the first login, the admin user/password by default: (admin/admin), the system will prompt you to change the password, you can change or cancel.
3. User login: admin (defaulted, administrator), user (ordinary user) or other newly-added users, to login after typing in the password.

4. Click [OK] button to enter the Web preview interface. As shown below:

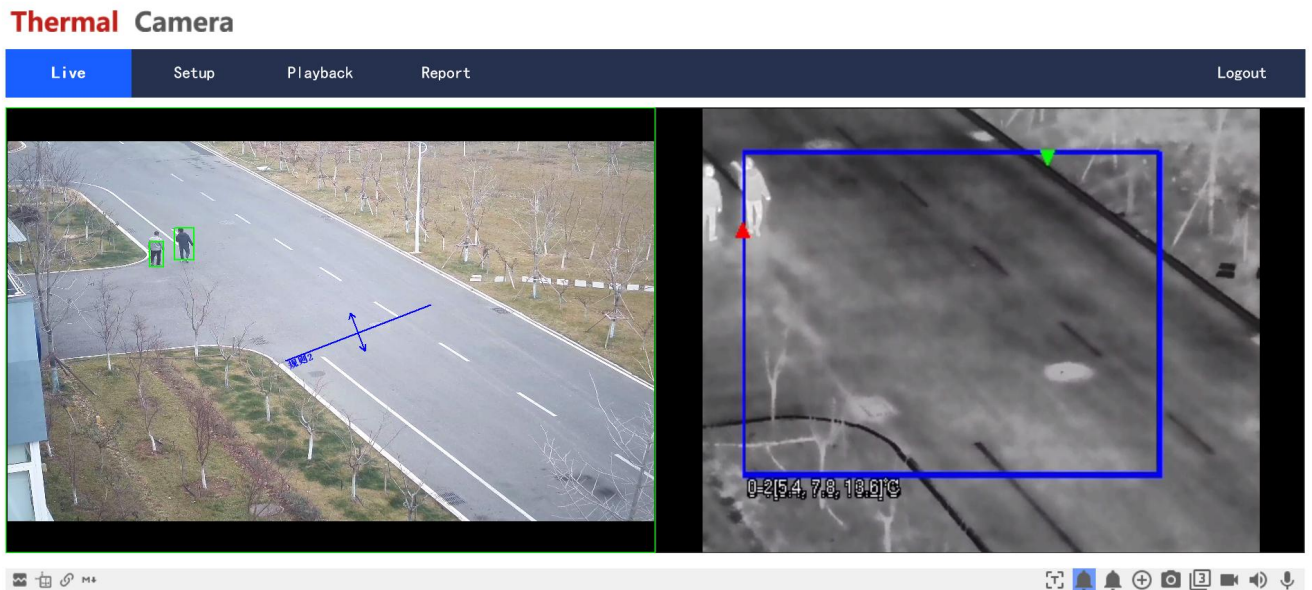

Figure 3.2 Preview Interface

### 3.3 Main Interface Description

On the Web interface of the camera, you can perform operations and configurations such as preview, video playback, temperature measurement analysis, intelligent analysis, and parameter setting.

1. Preview: Used to preview and control the monitoring screen of the camera.
2. Playback: Search, replay and download videos stored in TF card or in local storage by time.
3. Setup: enter into the setup interface to perform system configuration and function configuration, including temperature measurement analysis, event management and intelligent analysis.
4. Report: query and export historical data related to temperature measurement analysis.

## **Appendix A Camera Maintenance**

### **Lens Maintenance**

The lens surface is coated with anti-reflective coating. When contaminated with dust, grease, and fingerprints, harmful substances will be produced, therefore the degraded performance, scratches or mold will be caused. Once dirt is found, please follow the following methods.

Dust stained: Use an oil-free soft brush or a blower ball to gently flick the dust off.

Grease stained: Gently wipe away water or oil with a soft cloth and dry it, then rub it outward from the center of the lens using an oil-free cotton cloth or lens cleaner coated with alcohol or lens cleaner. If it is still not clean, you can change the cloth and wipe it several times.

### **Network Safety Maintenance**

In order to ensure the network security of the camera, it is recommended that you conduct regular network security assessment and maintenance of the network system. Corresponding professional technical service can be offered.

## Appendix B Emissivity of Common Materials

Materials	Temperature (°C)	Emissivity
Water	0~100	0.95~0.98
Soil(dry)	20	0.92
Soil(wet)	20	0.95
Woods	17	0.962
Sand	20	0.9
Sandstone	19	0.909~0.935
PVC plastic	70	0.93
Asphalt	20	0.967
Paint	70	0.92~0.94
Wallpaper	20	0.85~0.90
Cloth	20	0.98
Concrete	20	0.92
Pavement surface	5	0.974
Smooth china	20	0.92
Ceramic tile	17	0.94
Gypsum	17	0.86
Bricks	35	0.94
Hard rubber	0~100	0.89
Carbon	20~400	0.95~0.97
Granite(rough)	20	0.879
Cold rolled steel	70	0.09
Oxidized steel	50	0.88
Copper	20	0.07
Oxidized copper	50	0.6~0.7